

◆Features:

- ◆Super high flux output and high luminance
- ◆Extremely wide viewing angle
- ◆Suitable for all SMT assembly and solder process
- ◆Available on tape and reel
- ◆Package:3000pcs/reel
- ◆ROHS compliant

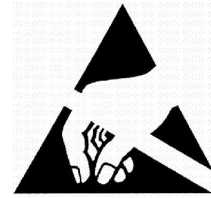

ATTENTION
OBSERVE PRECAUTIONS
FOR HANDLING
ELECTROSTATIC
DISCHARGE
SENSITIVE
DEVICES

◆ABSOLUTE MAXIMUM RATING (Ta=25℃)

| Item | Symbol | Value | Unit |
|-----------------------------|--------|------------|------|
| Peak Forward Current | IFp | 60 | mA |
| Reverse Voltage | VR | 5.0 | V |
| Continuous Forward Current | IF | 20 | mA |
| Recommend Operating Current | IF | 18 | mA |
| Operating Temperature | Topr | -20 to 85 | ℃ |
| Storage Temperature | Tstg | -30 to 100 | ℃ |

◆CHARACTERISTICS (Ta=25℃)

| Parameter | Condition | Symbol | Min | Typ | Max | Units |
|---------------------|-----------|---------|-----|-----|-----|-------|
| Power Dissipation | IF=20mA | Pd | / | 60 | / | mw |
| Forward Voltage | IF=20mA | VF | 2.8 | 3.2 | 3.8 | v |
| Reverse Current | VR=5V | IR | / | / | 10 | μ A |
| Dominant Wavelength | IF=20mA | λ d | 450 | / | 465 | nm |
| Luminous Intensity | IF=20mA | IV | 100 | 250 | / | mcd |
| Full Viewing Angle | IF=20mA | 2 θ 1/2 | / | 120 | / | deg |

◆PACKAGE DIMENSIONS

◆实物图

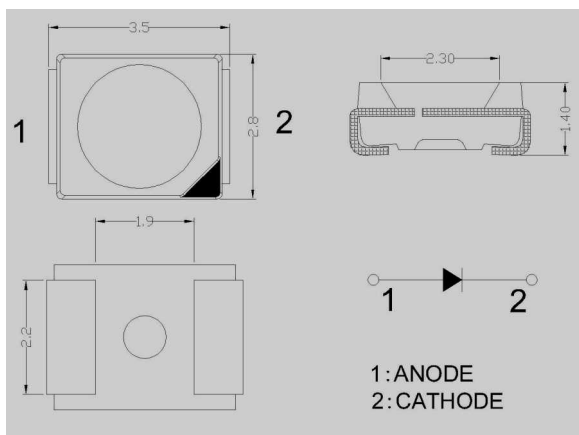

REMARK: 1:1

| | | | | | | |
|---------|------------|--------------|------------|-----------|--------------|----------|
| Date | 2013-03-03 | Page | 1/1 | Model No. | SD3528BN-0.5 | CHECKED |
| REV No. | A0 | Document No. | 1903528009 | CUSTOMER | | APPROVED |

NOTE: Testing tolerance: VF±0.1V, IV(Φv) ±10%, 2 θ 1/2 ±10% , CCT (λ D) ±15%;